

G.M. Advanced Fencing & Security Technologies Ltd



V-ALERT

Intrusion Detection System



G.M. Advanced Fencing & Security Technologies Ltd

14 Taas St. P.O. Box 2327 Industrial Area Kfar Saba 44425 Israel

Tel: 972-9-7662965 Fax: 972-9-7662964

E-mail: info@gmsecurity.com Website: www.gmsecurity.com

This objective of this document is to provide more detailed information about the V-Alert Perimeter Intrusion Detection System. The development of the system is a continuing process and GM is continually updating and amending versions of the V-Alert System with respect to the physical system components and electronic features. GM Ltd reserves the right to amend the contents of this document and technical features of the system. Installation of the system is to be undertaken by an approved GM Perimeter Security Fencing installer.

CONFIDENTIAL – FOR CUSTOMER USE ONLY
Copyright GM Advanced Fencing & Security Technologies Ltd

V-Alert Intrusion Detection Security System

1. INTRODUCTION

- 1.1. GM's latest technological development is the V-Alert Intrusion Detection System. This system detects intrusion attempts caused by cutting or climbing the fencing barrier or attempts to break through walls or move protected objects.
- 1.2. Vibration detection systems already exist on the market and they have been proven to be an acceptable and reliable type of detection system. These systems are used worldwide for a wide range of security applications.
- 1.3. **GM's V-Alert Intrusion Detection System will make significant technological changes and improvements to existing systems, and will be regarded in the Perimeter Security Field as a technological breakthrough.**

2. SYSTEM ADVANTAGES

- 2.1. The major advantages of GM's V-Alert Intrusion Detection System are:
 - Higher detection resolution - each sensor provides an independent alarm indication.
 - Easier installation procedure.
 - No moving parts – parts will not wear out.
 - The ability to suit a wider range of applications due to the systems technological capabilities.
 - The system can be installed on electric fencing wires or on fencing wires of conventional fencing and on walls.
 - Each sensor has a unique ID
 - The sensitivity of each sensor can be changed according to the barrier on which the sensor is installed.
 - Can detect intrusion attempts on walls, window bars or other solid structures or objects.
- 2.2. Comparison tables are included below in Annex 1 and Annex 2 respectively
 - 2.2.1. Annex 1: V-Alert compared with other Vibration Detection Systems
 - 2.2.2. Annex 2: V-Alert compared with other fence-mounted systems

3. SYSTEM DESCRIPTION

3.1. V-Alert Sensors and Cable (Part No. VAF3)

- 3.1.1. The system consists of a 4 ply twisted pair cable connecting V-Alert sensors spaced 3 m apart.
- 3.1.2. The sensor line is typically 150 m in length, consisting of 50 sensors.
- 3.1.3. The sensor + cable is to be connected to the existing fence on site approximately 120–170 cm above the ground level, depending on the nature and height of the existing fence barrier.
- 3.1.4. The V-Alert technology enables the installation on almost any fencing barrier without having to upgrade the existing fencing barrier.
- 3.1.5. Typical fencing barriers on which the V-Alert system can be installed include: Chain Link fencing, welded mesh fencing and other metal fabric fences.
- 3.1.6. The unique V-Alert Technology enables the installation on Barbed Wire fencing wires as well as on Electric Security Fencing wires.
- 3.1.7. The system can also be installed on walls where it will detect any attempt at breaking through the wall.
- 3.1.8. The system will detect an alarm as a result of CUTTING or CLIMBING of the fence structure.
- 3.1.9. The V-Alert System is designed in such a way so that an intrusion attempt will be detected to an alarm detection resolution of 3 m.

3.2. Zone Processor Card (Part No. VAPC) and Cabinet (Part No. VAC)

- 3.2.1. The V-Alert Zone Processing Card is installed in an outdoor cabinet containing the V-Alert Zone Processor Card next to or in close proximity to the perimeter fence.
- 3.2.2. The V-Alert Zone Processing Card can be used to connect 2 sensor cable lines, each line consisting of 50 sensors, or 150 m of sensor cable.
- 3.2.3. The cabinets are typically installed every 300 m, controlling 2 V-Alert sensor lines of 150 m each line.
- 3.2.4. The outdoor cabinet will contain a power supply unit and 12V battery to ensure that the system continues to operate in the event of a power supply failure. The size of the battery is to be determined depending on the amount of back-up time required.
- 3.2.5. The V-Alert Zone Processor Card is designed to work via RS 232 connection with the DUAL COMM Communication Card (see explanation below) for the transmission of the alarm indications to the Central Control Panel/Receiver.
- 3.2.6. It is possible to output the alarm indications by relays with the addition of a 10 relay V-Alert Relay Card.
- 3.2.7. 110/220 V Mains Electricity points must be provided for electricity supply to each outdoor cabinet. If it is not possible to supply 110/220V power supply to the cabinets then other methods of electricity supply can be considered.
- 3.2.8. The cabinets can be heated if the winter weather temperatures are very low.
- 3.2.9. The parameters of each individual sensor are programmed using GM's V-Alert Software application. The sensor parameters are programmed by connecting the software application to the USB port on the V-Alert Processing Card in order to set the parameters of the sensor lines connected to the Processing Card.

4. TYPICAL SYSTEM CONFIGURATION

4.1. DUAL COMM Communication System

- 4.1.1. The alarm indications from the V-Alert Sensor line will be integrated with GM's DUAL COMM Communication system.
- 4.1.2. The DUAL COMM system operates as a wireless and/or hardwired communication system (RS485 Communication)
- 4.1.3. The DUAL COMM communication system consists of a communication card that transmits via wireless or hardwired communication to the DUAL COMM Control Panel/Receiver.
- 4.1.4. The DUAL COMM Communication Card will be installed inside the outdoor cabinets that hold the V-Alert zone-processing card.
- 4.1.5. For installations not using the DUAL COMM Communication System, 10 relay contacts are available on the V-Alert Relay Card.

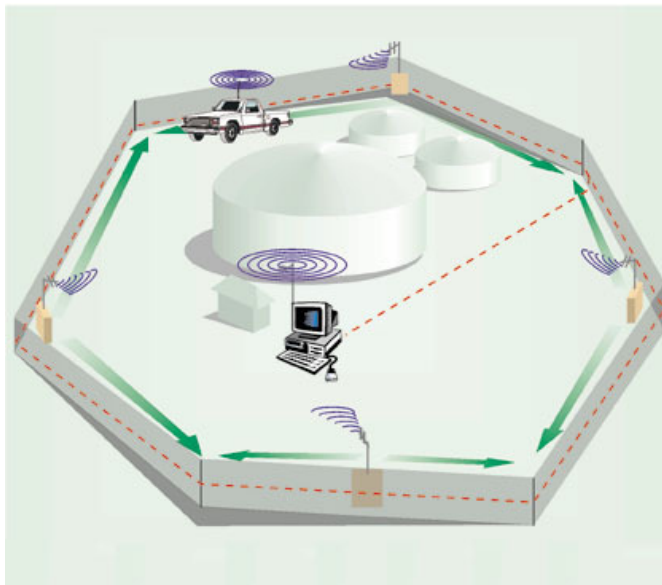

4.2. SecurCOMM Central Control System Software

- 4.2.1. The DUAL COMM Communication system supplied can be integrated with a computer-controlled system that will consist of GM's **SecurCOMM** System Software.
 - 4.2.2. This **SecurCOMM** software will centralize all the alarm signals from the perimeter security fence (V-Alert System and other systems such as the Electric Security Fence), show the site in the form of a synoptic map, and maintain and store an events log of all the events occurring in the site.
 - 4.2.3. Integration with CCTV systems can be completed by matching the communication protocol of the DUALCOMM Communication System.
- 4.3. Technical Drawings and Block Diagrams of typical system configurations can be found in the following annexes:
- 4.3.1. Annex 3: Various Technical Drawings
 - 4.3.2. Annex 4: Block Diagram Complete System

5. PRINCIPLE OF OPERATION

- 5.1. The V-Alert sensor consists of a small printed circuit board containing electronic components that is encased in a weatherproof epoxy housing. Electronic components in the sensor detect movement on the fence and convert these movements into electronic signals.
- 5.2. There are no moving parts in the sensor that are a common source of false alarms in other vibration detection systems.
- 5.3. Each individual sensor processes data resulting from movements on the fence line and transmits this data to the Zone Processor Card.
- 5.4. Each individual sensor has its own ID.
- 5.5. The continuous data flow from individual sensors is processed and analysed by the Zone Processor Card.
- 5.6. The Zone Processor Card compares the data from each individual sensor in order to detect whether the movement on the fence line is an intrusion attempt or not.
- 5.7. Advanced algorithm technology enables the system to detect a REAL intrusion attempt that is usually caused by climbing or cutting of the fence or fence wires.
- 5.8. The system is monitoring changes in the data flow from each individual sensor resulting in an alarm detection resolution of 3m or an alarm detection resolution to each individual sensor.
- 5.9. An example of the operation of the system in operation can be described as follows:

Strong wind on the sensor line causes an entire group of sensors to move. Each individual sensor will detect movement, and the electronic signals or data will flow from each individual sensor to the zone-processing card. If all the data received by sensors in that group of sensors show similar changes, then no alarm will be activated. The Zone Processor Card will only alarm when an individual sensor or number of sensors transmit data that is DIFFERENT to data received by the larger group of sensors at that given moment. The system adapts to the constantly changing conditions on the fence.

- 5.10. More details about the operation and installation of the V-Alert Intrusion Detection System can be found in the installation guides and user manuals, a list of which can be found in Annex 5.
- 5.11. The Technical Specifications of the V-Alert System can be found in Annex 6.

Annex 1: UNIQUE PRODUCT ADVANTAGES

Comparison of V-Alert with existing Vibration Detection Systems

The following table describes the major advantages of GM's V-Alert System when compared with the technology and capabilities of existing systems:

Advantage	GM's V-Alert System	OTHER available Vibration Detection Systems
Individual Sensor setting	The sensitivity of each individual sensor can be adjusted or set according to the fence, barrier or object on which the V-Alert Sensor is installed.	It is not possible to change the sensitivity of mechanical inertial sensors or the sensitivity of sensors using piezo-electric technology. Changing the Piezo-electric sensor sensitivity requires replacing the entire sensor line.
NO moving parts.	No moving parts means that parts cannot wear out and do not have to be replaced. The sensor consists entirely of electronic parts. The system does not rely on the mechanical movement of sensor parts in order to detect an intrusion.	Most systems rely on a mechanical-inertial sensor that has moveable parts that are prone to wear out over time. The moving part can lock as a result of dust entering the sensor which causes the sensor to malfunction. The use of mechanical inertial or Piezo electric components rely on a physical movement of the detection elements of the sensor. Adverse weather conditions can therefore be a common source of false alarms in these types of systems. Changes in the fence structure can cause the setting of the vibration sensor to be disturbed, which can also be a cause of false alarms.
Independent indications from each sensor	EACH sensor communicates independent data to a zone processor card. The data from sensors is compared with adjacent sensors in order to establish whether the alarm is a real alarm or not, together with the exact location of the alarm.	Usually one sensor provides an alarm signal, but this sensor is part of a GROUP or line of sensors. There is no independent data received from individual sensors and it is not possible to identify which sensor is malfunctioning.
Higher detection resolution	The system has a detection resolution to the level of each sensor or a 3 m detection resolution.	Detection zones are typically between 100 m to 150 m per zone.

Annex 1 (Continued)

Advantage	GM's V-Alert System	OTHER available Vibration Detection Systems
Controlled by adaptive digital technology and Low False alarm Rate	<p>The constant flow of data from each sensor enables the system to ADAPT continuously to changes in environmental conditions.</p> <p>Low false alarm rate because of the systems independent sensor data flow. Strong wind for example will be experienced at the same time by ALL of the sensors in that area.</p>	<p>Sensors can be adversely affected by changes in environmental conditions, which can be a source of false alarms.</p> <p>A typical method of reducing false alarms is to use a meteorological unit that lowers the sensitivity of the system in adverse weather conditions.</p> <p>However this also lowers the sensitivity and hence detection capability of the system during an intrusion attempt.</p>
Simpler and faster installation procedure	<p>The sensors can be installed (on the fence/fence wires, wall etc) without any need to level or calibrate the sensors.</p> <p>No expertise is required to install the sensors on the fence.</p> <p>This results in LOWER INSTALLATION COSTS</p>	<p>Sensors need to be levelled and set in order to operate without false alarms.</p> <p>The time taken to install the system is therefore longer. This results in increased costs of installation.</p>
No maintenance required	<p>The sensors do not require any post installation maintenance procedures</p>	<p>Sensors may have to be reset and levelled in the event of movements of the fence infra structure</p>
Wider range of applications	<p>The system suits a wider range of applications due to the systems technological capabilities. The system can be installed on electric fencing wires, on fencing wires of conventional fencing, on walls and on burglar bars</p>	<p>Competing systems have to have a suitable infrastructure on which to be installed.</p> <p>A suitable infra-structure may have to built or an existing infra structure may have to be renovated to meet the needs of the system.</p> <p>This may be a limiting factor of the system or can add extra expenses to the total installed costs of the system.</p>

Annex 2: UNIQUE PRODUCT ADVANTAGES

Comparison of V-Alert with other Sensor Cable, Fence Mounted Intrusion Detection Systems:

Subject	GM's V-Alert System	OTHER Sensor Cable Fence Mounted Intrusion Detection Systems (Fiber Optic, Coaxial, microphonic cable etc)
Sensitivity and False Alarm Rate	<p>The sensor has no moving parts and consists entirely of electronic parts. The system is ADAPTING continuously to environmental conditions and as a result has a very low level of false and nuisance alarms.</p> <p>There is no need to lower the sensitivity of the system in order to filter out possible problems caused by environmental conditions.</p>	<p>Mechanical movement of the sensor cable caused by cutting or climbing the fence is interpreted as intrusion attempt. However these systems are more sensitive to false and nuisance alarms caused by extreme environmental conditions.</p> <p>The solution of most systems is to lower the sensitivity of the system in order to prevent false alarms. This however also lowers the detection capability of the system, therefore lowering the level of security in that installation.</p>
Alarm detection resolution	<p>EACH sensor communicates independent data to a zone processor card. The data from sensors is compared with adjacent sensors in order to establish whether the alarm is a real alarm or not, together with the exact location of the alarm.</p> <p>The system typically operates on a 3 m alarm detection resolution.</p>	<p>Usually the entire sensor line zone provides an alarm signal. Detection zone lengths are typically 100 to 150 m, unless more zone processor cards are installed.</p> <p>There is no independent data received from individual sensors.</p>
Individual Sensor setting	<p>The sensitivity of each individual sensor can be adjusted or set according to the fence, barrier or object on which the V-Alert Sensor is installed.</p>	<p>It is not possible to change the sensitivity of sensor cables technologies.</p>

Annex 2 (Continued)

Subject	GM's V-Alert System	OTHER Sensor Cable Fence Mounted Intrusion Detection Systems (Fiber Optic, Coaxial, microphonic cable etc)
Fence Infra Structure	<p>The system can be installed on a wider range of conventional fences including electric fencing wires, and fences that are in a relatively bad condition.</p> <p>The adaptive capability of the sensor causes the sensor to adapt to the conditions on the fence/fence wires.</p>	<p>The fence-mounted systems require the fence to be in a good condition. Otherwise the system will be prone to a high level of false alarms.</p> <p>The fence has to be maintained in a good condition in order to maintain a good detection capability.</p> <p>The installation on electric fence wires or barbed wire fences is not possible.</p>
Wider range of applications	<p>The system suits a wider range of applications due to the systems technological capabilities. The system can be installed on electric fencing wires, on fencing wires of conventional fencing, on walls and on burglar bars</p>	<p>Competing systems have to have a suitable infrastructure on which to be installed.</p> <p>A suitable infra-structure may have to be built or an existing infra structure may have to be renovated to meet the needs of the system.</p> <p>Sensor Cables systems cannot be installed on walls, only on specific types of fences.</p>

Annex 3: Technical Drawings

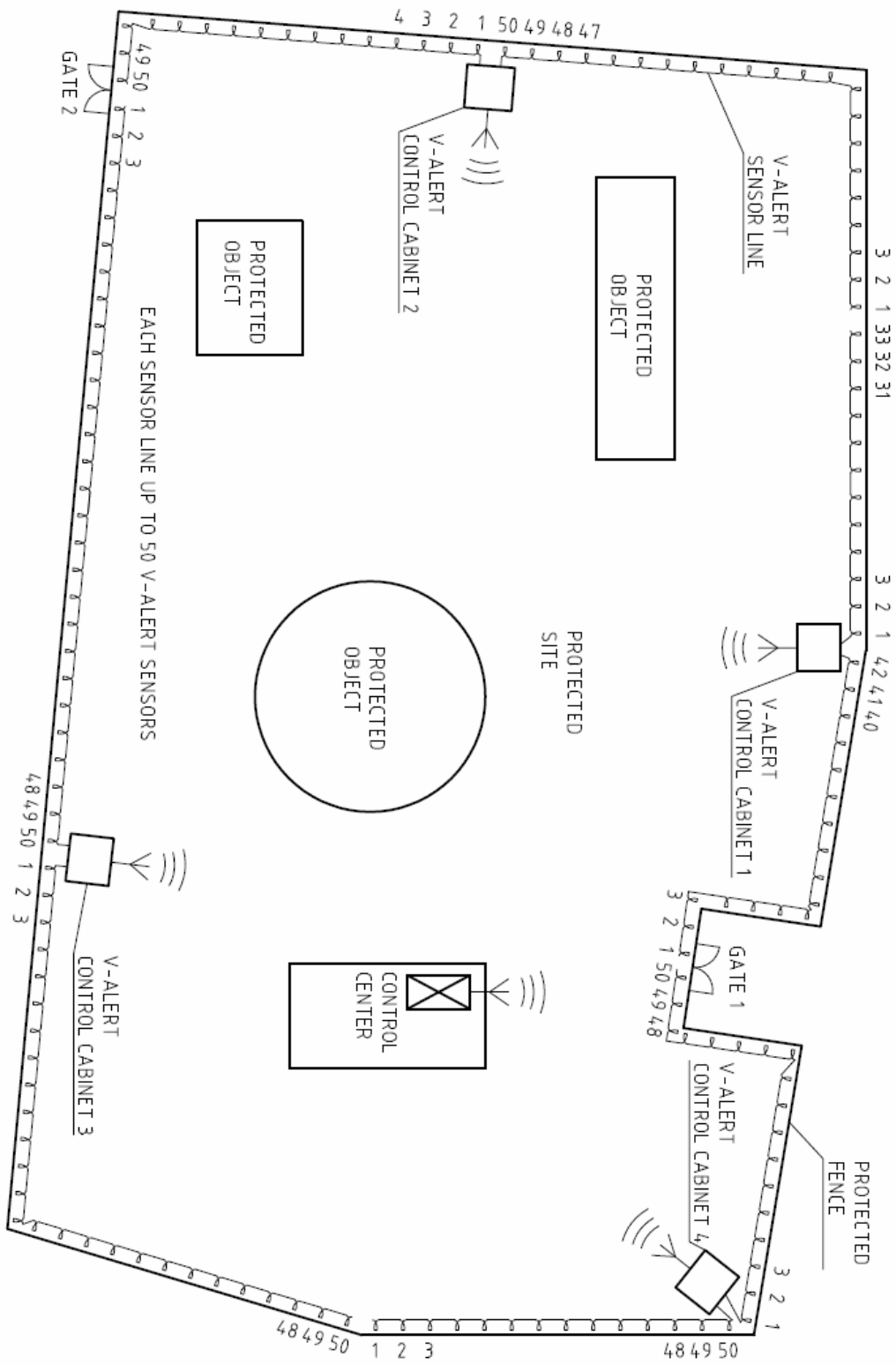

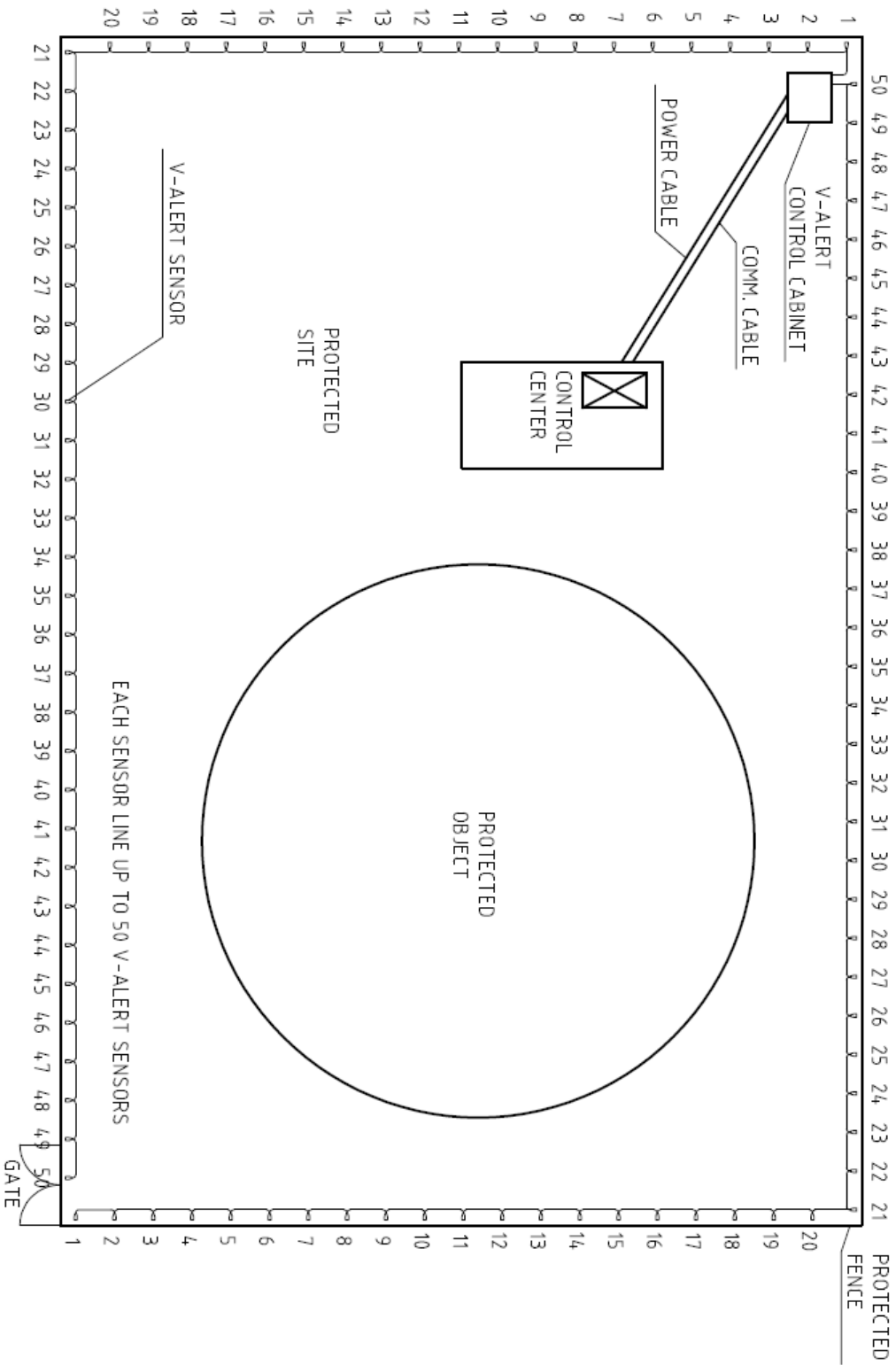

1 2 3 4 5 6 7 8 9 10 11 12 13 14 15 16 17 18 19 20 21

50 49 48 47 46 45 44 43 42 41 40 39 38 37 36 35 34 33 32 31 30 29 28 27 26 25 24 23 22 21

1 2 3 4 5 6 7 8 9 10 11 12 13 14 15 16 17 18 19 20 21

50 49 48 47 46 45 44 43 42 41 40 39 38 37 36 35 34 33 32 31 30 29 28 27 26 25 24 23 22 21

1 2 3 4 5 6 7 8 9 10 11 12 13 14 15 16 17 18 19 20 21

50 49 48 47 46 45 44 43 42 41 40 39 38 37 36 35 34 33 32 31 30 29 28 27 26 25 24 23 22 21

1 2 3 4 5 6 7 8 9 10 11 12 13 14 15 16 17 18 19 20 21

50 49 48 47 46 45 44 43 42 41 40 39 38 37 36 35 34 33 32 31 30 29 28 27 26 25 24 23 22 21

1 2 3 4 5 6 7 8 9 10 11 12 13 14 15 16 17 18 19 20 21

50 49 48 47 46 45 44 43 42 41 40 39 38 37 36 35 34 33 32 31 30 29 28 27 26 25 24 23 22 21

1 2 3 4 5 6 7 8 9 10 11 12 13 14 15 16 17 18 19 20 21

50 49 48 47 46 45 44 43 42 41 40 39 38 37 36 35 34 33 32 31 30 29 28 27 26 25 24 23 22 21

1 2 3 4 5 6 7 8 9 10 11 12 13 14 15 16 17 18 19 20 21

50 49 48 47 46 45 44 43 42 41 40 39 38 37 36 35 34 33 32 31 30 29 28 27 26 25 24 23 22 21

1 2 3 4 5 6 7 8 9 10 11 12 13 14 15 16 17 18 19 20 21

50 49 48 47 46 45 44 43 42 41 40 39 38 37 36 35 34 33 32 31 30 29 28 27 26 25 24 23 22 21

1 2 3 4 5 6 7 8 9 10 11 12 13 14 15 16 17 18 19 20 21

50 49 48 47 46 45 44 43 42 41 40 39 38 37 36 35 34 33 32 31 30 29 28 27 26 25 24 23 22 21

1 2 3 4 5 6 7 8 9 10 11 12 13 14 15 16 17 18 19 20 21

50 49 48 47 46 45 44 43 42 41 40 39 38 37 36 35 34 33 32 31 30 29 28 27 26 25 24 23 22 21

1 2 3 4 5 6 7 8 9 10 11 12 13 14 15 16 17 18 19 20 21

50 49 48 47 46 45 44 43 42 41 40 39 38 37 36 35 34 33 32 31 30 29 28 27 26 25 24 23 22 21

1 2 3 4 5 6 7 8 9 10 11 12 13 14 15 16 17 18 19 20 21

50 49 48 47 46 45 44 43 42 41 40 39 38 37 36 35 34 33 32 31 30 29 28 27 26 25 24 23 22 21

1 2 3 4 5 6 7 8 9 10 11 12 13 14 15 16 17 18 19 20 21

50 49 48 47 46 45 44 43 42 41 40 39 38 37 36 35 34 33 32 31 30 29 28 27 26 25 24 23 22 21

1 2 3 4 5 6 7 8 9 10 11 12 13 14 15 16 17 18 19 20 21

50 49 48 47 46 45 44 43 42 41 40 39 38 37 36 35 34 33 32 31 30 29 28 27 26 25 24 23 22 21

1 2 3 4 5 6 7 8 9 10 11 12 13 14 15 16 17 18 19 20 21

50 49 48 47 46 45 44 43 42 41 40 39 38 37 36 35 34 33 32 31 30 29 28 27 26 25 24 23 22 21

1 2 3 4 5 6 7 8 9 10 11 12 13 14 15 16 17 18 19 20 21

50 49 48 47 46 45 44 43 42 41 40 39 38 37 36 35 34 33 32 31 30 29 28 27 26 25 24 23 22 21

1 2 3 4 5 6 7 8 9 10 11 12 13 14 15 16 17 18 19 20 21

50 49 48 47 46 45 44 43 42 41 40 39 38 37 36 35 34 33 32 31 30 29 28 27 26 25 24 23 22 21

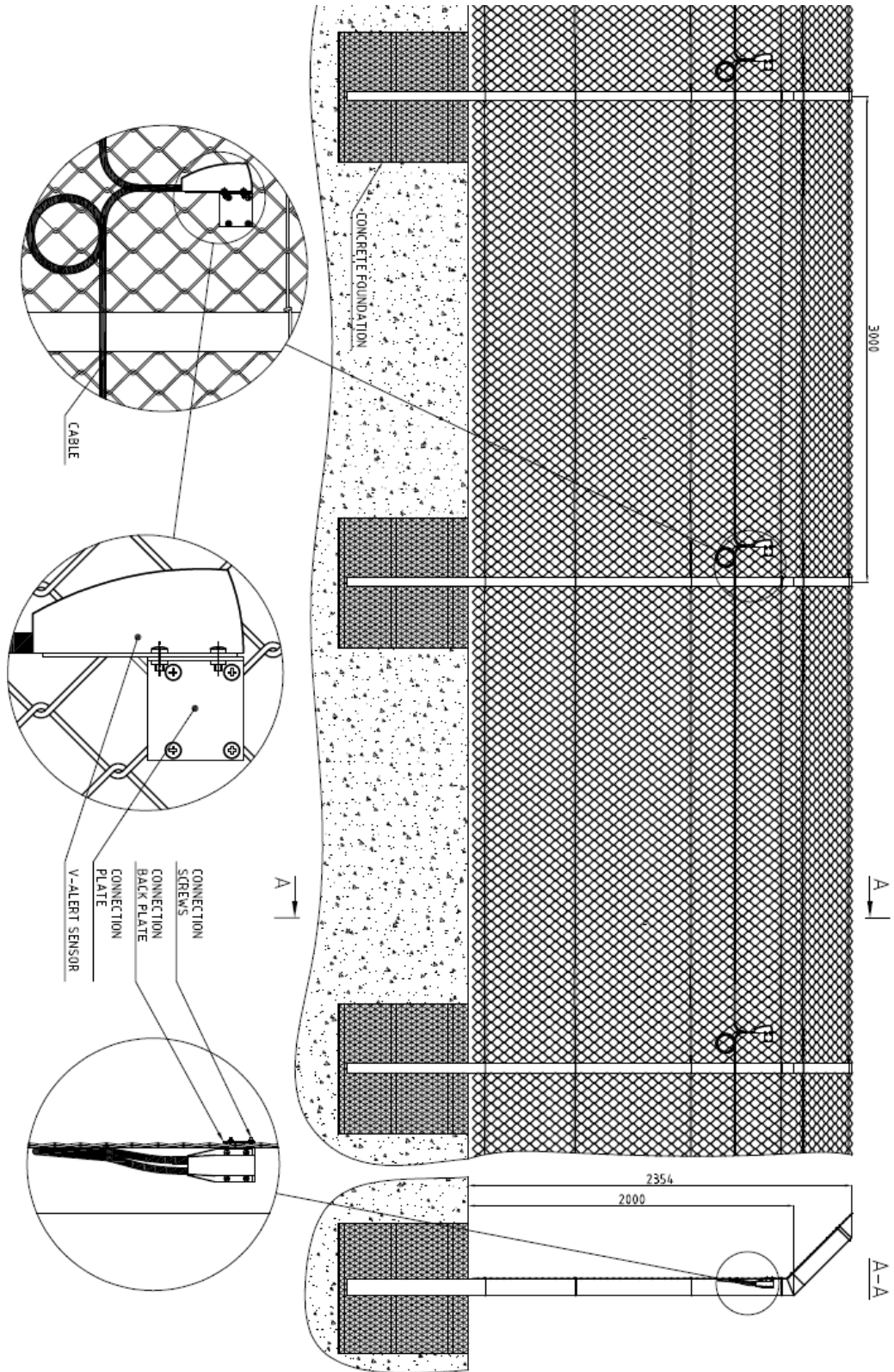

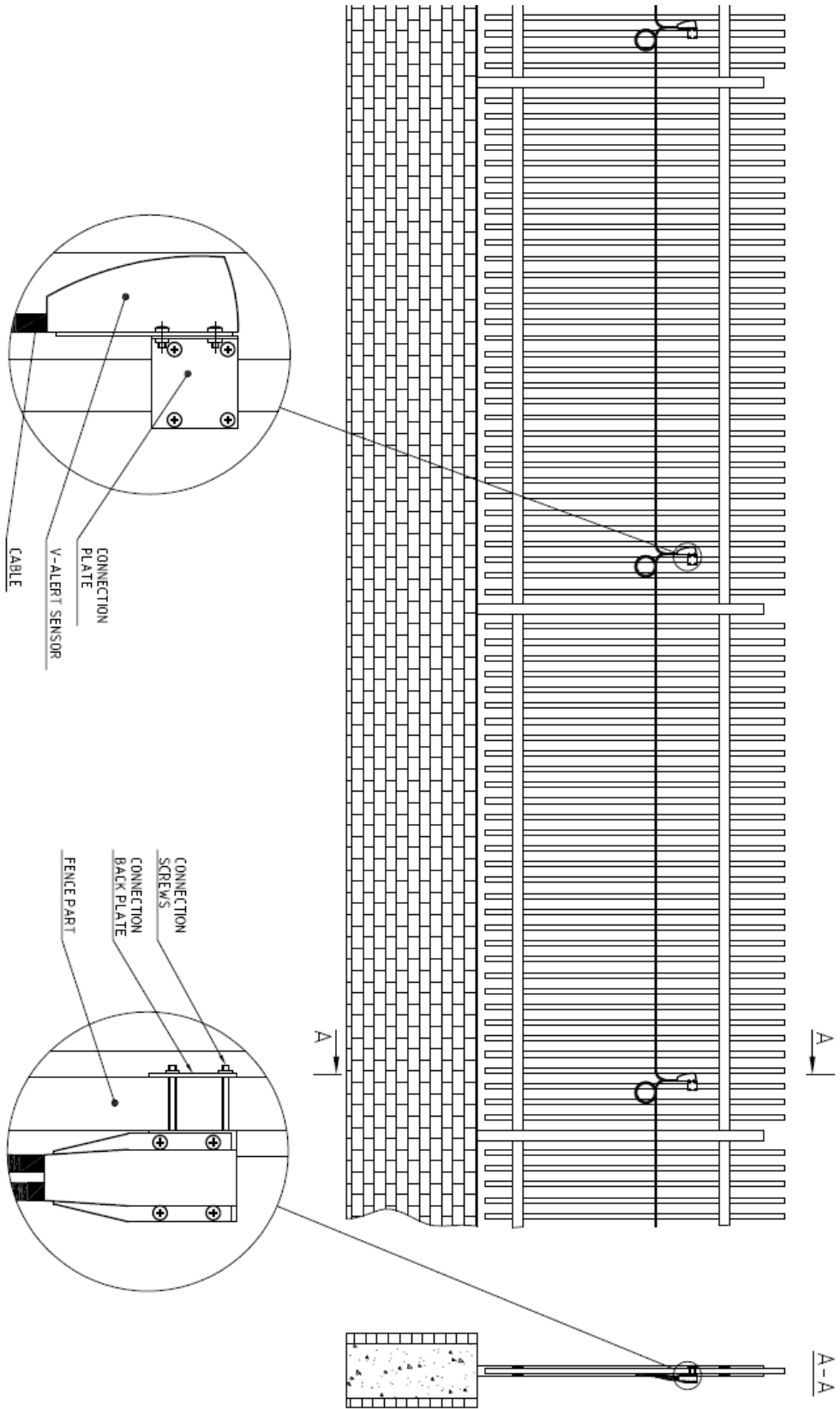

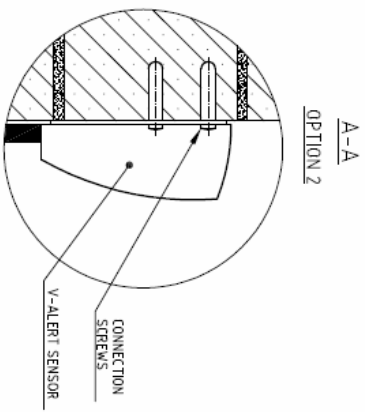
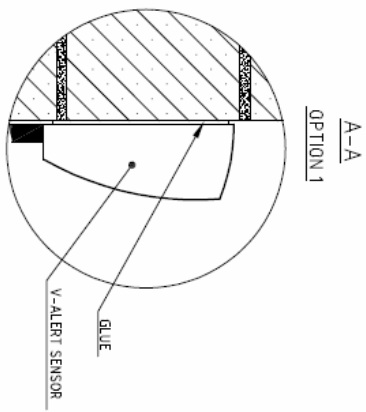
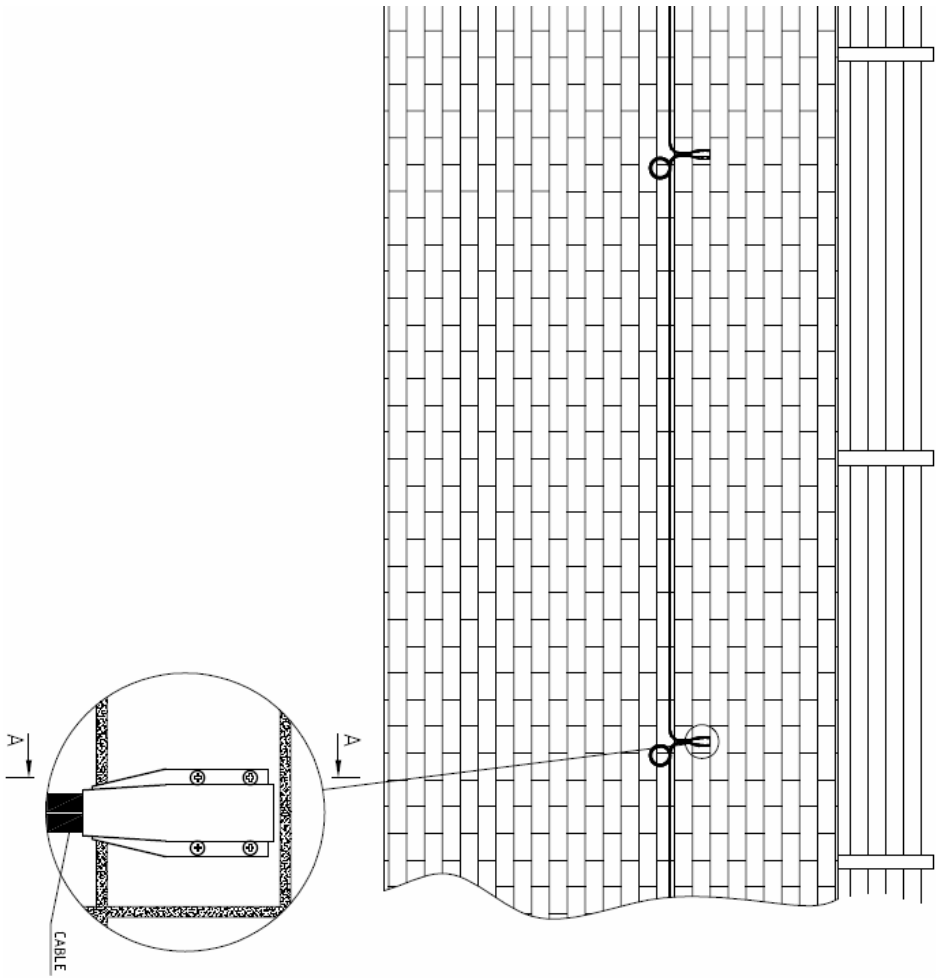

Annex 4: Block Diagram: V-Alert Communication Integration

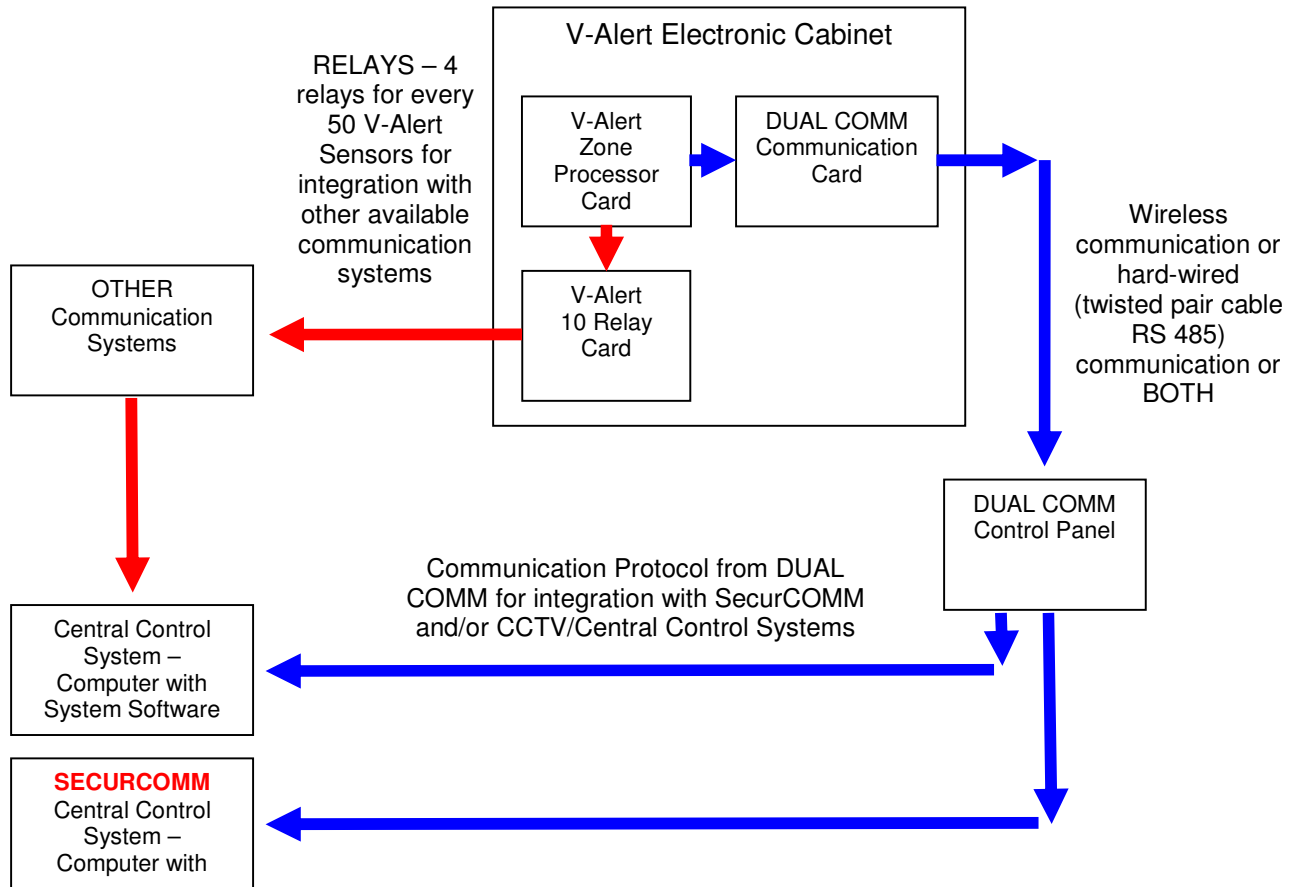

Explanation:

1. **BLUE** Line denotes communication via DUAL COMM Communication System – providing alarms from each individual sensor.
2. **RED** line denotes communication via V-Alert RELAY card – providing alarms from groups of sensors.

Annex 5: List of GM MANUALS and SOFTWARE APPLICATIONS used by the installer

SOFTWARE APPLICATIONS	DESCRIPTION
V-AlertCOMM Settings Manager	Application used by the installer to set the V-Alert Sensor sensitivity and detection parameters.
Data Storage Application	Application used by the installer to read the V-Alert Sensor data flow coming from each individual sensor.
SecurCOMM Integrated Security Site Management Application	Central Control Software application.
Password Generator	Password Generator generates a password required to make changes to the V-Alert Sensor and Card Settings when using the V-AlertCOMM Settings Manager.
MANUALS & GUIDES	DESCRIPTION
V-Alert Installation Manual	General Installation guide for installing the V-Alert Sensors.
V-AlertCOMM Settings Manager Manual	User guide for the installer – V-Alert sensor standard sensitivity and alarm detection parameters.
V-Alert Card and Sensor Settings Manual	User guide for the installer – more detailed settings of the V-Alert Card and Sensor Settings sensitivity and alarm detection parameters
V-Alert Sensor Loader Manual	The Sensor Loader is a small device required to number the V-Alert Sensors. The user guide explains the use of the Sensor Loader.
Data Storage Installation Manual	Manual explaining the installation of the Data Storage Application.
Data Storage User Guide	User guide explaining the use of the Data Storage Application.
SecurCOMM Installation Manual	Manual explaining the installation of the SecurCOMM Application.
SecurCOMM User's Guide	User guide explaining the use of the SecurCOMM Application.

Annex 6: V-Alert Technical Specifications

V-Alert Processor Card	
Operating Voltage	9-14 V
Input Current	50-250mA
Number of Sensor Line outputs	2 sensor lines
Number of sensors per sensor line	50 sensors max (standard)
Current Limit per sensor line	1A Poly Fuse
Communication – sensor line	RS 485 Balanced 120 Ω HALF DUPLEX
Communication Frame	9600 8N1
Communication to PC	RS 232
Communication Frame to PC	19200 8N1
Processor Card Dimensions	200 x 200 mm
Memory size	64K
RTC (Real Time Clock)	Hour – Minutes - Seconds
Mode	MASTER
Programmable Parameters	Using V-AlertCOMM Settings Manager
X-Axis – adjust alarm value	
Y-Axis – adjust alarm value	
Output Signals: Relays for sensor lines	4 Relays for each sensor line 1 Relays for sensor line CUT for each sensor line
Communication to PC	Individual Sensor Level
Communication to DUAL COMM Communication system	Individual Sensor Level
SMS Communication	Individual Sensor Level
Flash memory	
Operating Temperature	-40 ° to + 70 ° C
Storage Temperature	-40 ° to + 70 ° C
Humidity	20% to 95 %
Lightning Protection	ESD (Electro Static Discharge)

V-Alert Sensor	
Operating Voltage	8-13.8 V
Power consumption	10 mA
Communication	RS 485 HALF DUPLEX
Communication Frame	9600 8N1
Number axes	2
Angle between axes	90 °
Detection Method	PEAK DETECT
Programming	5 pin connector
Size	\varnothing 20 mm x 50 mm
Cable	2 x 2 x 0.5 mm Shielded Twisted Pair
Minimum Sensitivity	\pm 0.02 g per axis
Maximum Sensitivity	\pm 2 g per axis
Cross Talk	40 DB
Operating Temperature	-40 ° to + 70 ° C
Storage Temperature	-40 ° to + 70 ° C
Humidity	10% to 95 %
Operating Mode	SLAVE

